

LOCAÇÃO E SITUAÇÃO DA OBRA 06

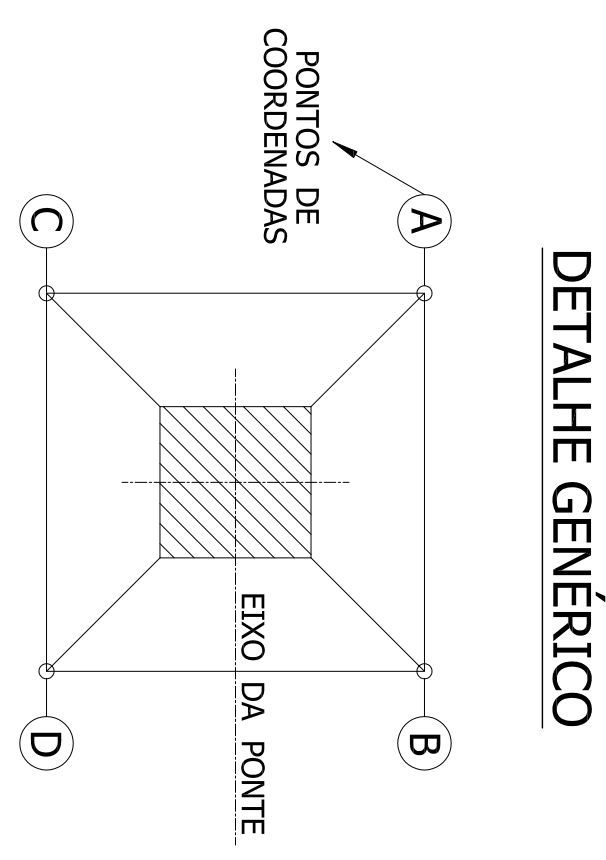

OBRA	PILARES	ESTACAS	COORDENADAS		BLOCOS		
			ESTE (X)	NORTE (Y)	ESTE (X)	NORTE (Y)	
PA-E01	21790+5,14	X = 737003,2607 Y = 9191840,5720	A	X = 737028,5076 Y = 91915181,3366	A	X = 737028,5076 Y = 91915181,3366	
			B	X = 737028,5076 Y = 91915181,3366		B	X = 737028,5076 Y = 91915181,3366
			C	X = 737028,5076 Y = 91915181,3366		C	X = 737028,5076 Y = 91915181,3366
			D	X = 737028,5076 Y = 91915181,3366		D	X = 737028,5076 Y = 91915181,3366
PB-E01	21790+5,14	X = 737031,1322 Y = 9191837,9143	A	X = 737032,4890 Y = 91915182,7393	A	X = 737032,4890 Y = 91915182,7393	
			B	X = 737032,4890 Y = 91915182,7393		B	X = 737032,4890 Y = 91915182,7393
			C	X = 737032,4890 Y = 91915182,7393		C	X = 737032,4890 Y = 91915182,7393
			D	X = 737032,4890 Y = 91915182,7393		D	X = 737032,4890 Y = 91915182,7393
P-(C+D) E01	21790+16,68	X = 737041,6875 Y = 9191842,8801	A	X = 737042,5300 Y = 91915184,2662	A	X = 737042,5300 Y = 91915184,2662	
			B	X = 737042,5300 Y = 91915184,2662		B	X = 737042,5300 Y = 91915184,2662
			C	X = 737042,5300 Y = 91915184,2662		C	X = 737042,5300 Y = 91915184,2662
			D	X = 737042,5300 Y = 91915184,2662		D	X = 737042,5300 Y = 91915184,2662
P1	21801+1,84	X = 737065,5096 Y = 9191850,7065	A	X = 737061,6546 Y = 91915183,7426	A	X = 737061,6546 Y = 91915183,7426	
			B	X = 737061,6546 Y = 91915183,7426		B	X = 737061,6546 Y = 91915183,7426
			C	X = 737061,6546 Y = 91915183,7426		C	X = 737061,6546 Y = 91915183,7426
			D	X = 737061,6546 Y = 91915183,7426		D	X = 737061,6546 Y = 91915183,7426
P2	21802+7,78	X = 737090,1192 Y = 9191858,9647	A	X = 737086,6640 Y = 91915183,3112	A	X = 737086,6640 Y = 91915183,3112	
			B	X = 737086,6640 Y = 91915183,3112		B	X = 737086,6640 Y = 91915183,3112
			C	X = 737086,6640 Y = 91915183,3112		C	X = 737086,6640 Y = 91915183,3112
			D	X = 737086,6640 Y = 91915183,3112		D	X = 737086,6640 Y = 91915183,3112
P3	21803+13,71	X = 738014,7287 Y = 9191887,1339	A	X = 738016,5376 Y = 91915182,1891	A	X = 738016,5376 Y = 91915182,1891	
			B	X = 738016,5376 Y = 91915182,1891		B	X = 738016,5376 Y = 91915182,1891
			C	X = 738016,5376 Y = 91915182,1891		C	X = 738016,5376 Y = 91915182,1891
			D	X = 738016,5376 Y = 91915182,1891		D	X = 738016,5376 Y = 91915182,1891
P4	21804+19,84	X = 738032,5383 Y = 9191875,3030	A	X = 738034,2900 Y = 91915181,1142	A	X = 738034,2900 Y = 91915181,1142	
			B	X = 738034,2900 Y = 91915181,1142		B	X = 738034,2900 Y = 91915181,1142
			C	X = 738034,2900 Y = 91915181,1142		C	X = 738034,2900 Y = 91915181,1142
			D	X = 738034,2900 Y = 91915181,1142		D	X = 738034,2900 Y = 91915181,1142
P5	21806+5,57	X = 738063,5478 Y = 9191883,4722	A	X = 738065,3242 Y = 91915182,4837	A	X = 738065,3242 Y = 91915182,4837	
			B	X = 738065,3242 Y = 91915182,4837		B	X = 738065,3242 Y = 91915182,4837
			C	X = 738065,3242 Y = 91915182,4837		C	X = 738065,3242 Y = 91915182,4837
			D	X = 738065,3242 Y = 91915182,4837		D	X = 738065,3242 Y = 91915182,4837
P6	21807+11,50	X = 738068,5573 Y = 9191891,6414	A	X = 738070,3242 Y = 91915182,4837	A	X = 738070,3242 Y = 91915182,4837	
			B	X = 738070,3242 Y = 91915182,4837		B	X = 738070,3242 Y = 91915182,4837
			C	X = 738070,3242 Y = 91915182,4837		C	X = 738070,3242 Y = 91915182,4837
			D	X = 738070,3242 Y = 91915182,4837		D	X = 738070,3242 Y = 91915182,4837
P7	21808+17,43	X = 738113,1689 Y = 9191898,8105	A	X = 738115,0297 Y = 91915181,0328	A	X = 738115,0297 Y = 91915181,0328	
			B	X = 738115,0297 Y = 91915181,0328		B	X = 738115,0297 Y = 91915181,0328
			C	X = 738115,0297 Y = 91915181,0328		C	X = 738115,0297 Y = 91915181,0328
			D	X = 738115,0297 Y = 91915181,0328		D	X = 738115,0297 Y = 91915181,0328
P8	21810+3,38	X = 738137,7764 Y = 9191907,9797	A	X = 738139,5872 Y = 91915182,4837	A	X = 738139,5872 Y = 91915182,4837	
			B	X = 738139,5872 Y = 91915182,4837		B	X = 738139,5872 Y = 91915182,4837
			C	X = 738139,5872 Y = 91915182,4837		C	X = 738139,5872 Y = 91915182,4837
			D	X = 738139,5872 Y = 91915182,4837		D	X = 738139,5872 Y = 91915182,4837
P9	21811+9,31	X = 738162,3880 Y = 9191916,1489	A	X = 738164,2092 Y = 91915182,4837	A	X = 738164,2092 Y = 91915182,4837	
			B	X = 738164,2092 Y = 91915182,4837		B	X = 738164,2092 Y = 91915182,4837
			C	X = 738164,2092 Y = 91915182,4837		C	X = 738164,2092 Y = 91915182,4837
			D	X = 738164,2092 Y = 91915182,4837		D	X = 738164,2092 Y = 91915182,4837
P-(C+D) E02	21812+14,48	X = 738188,2237 Y = 9191924,9845	A	X = 738190,0342 Y = 91915182,4837	A	X = 738190,0342 Y = 91915182,4837	
			B	X = 738190,0342 Y = 91915182,4837		B	X = 738190,0342 Y = 91915182,4837
			C	X = 738190,0342 Y = 91915182,4837		C	X = 738190,0342 Y = 91915182,4837
			D	X = 738190,0342 Y = 91915182,4837		D	X = 738190,0342 Y = 91915182,4837
P9-E02	21819+6,02	X = 738187,6692 Y = 9191928,3887	A	X = 738189,4800 Y = 91915182,4837	A	X = 738189,4800 Y = 91915182,4837	
			B	X = 738189,4800 Y = 91915182,4837		B	X = 738189,4800 Y = 91915182,4837
			C	X = 738189,4800 Y = 91915182,4837		C	X = 738189,4800 Y = 91915182,4837
			D	X = 738189,4800 Y = 91915182,4837		D	X = 738189,4800 Y = 91915182,4837
PA-E02	21819+6,02	X = 738188,7764 Y = 9191929,0489	A	X = 738190,5872 Y = 91915182,4837	A	X = 738190,5872 Y = 91915182,4837	
			B	X = 738190,5872 Y = 91915182,4837		B	X = 738190,5872 Y = 91915182,4837
			C	X = 738190,5872 Y = 91915182,4837		C	X = 738190,5872 Y = 91915182,4837
			D	X = 738190,5872 Y = 91915182,4837		D	X = 738190,5872 Y = 91915182,4837

02		REVISÃO DO PROJETO EXECUTIVO																			
01		REVISÃO GERAL																			
Nº		DISCRIMINAÇÃO		REVISORES		EMITENTE		VERIFICAÇÃO		APROVAÇÃO		CÓDIGO		DOCUMENTOS DE REFERENCIA		OBJETO		RESERVA		REVISÃO	